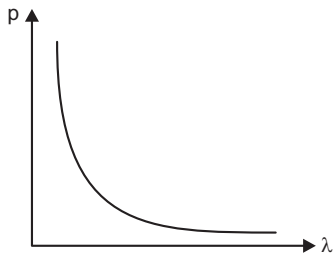

BSEH MODEL PAPER (2024-25)

Marking Scheme

SECTION-A

- | | | |
|-----|---|---|
| 1. | (c) $^{17}\text{O}_8$. | 1 |
| 2. | (b) magnitude of magnetisation. | 1 |
| 3. | (b) speed. | 1 |
| 4. | (d) first decreases to become zero and then increases. | 1 |
| 5. | (b) $\frac{I_0}{2}$. | 1 |
| 6. | (b)  | 1 |
| 7. | (b) $\frac{R}{2}$. | 1 |
| 8. | (a) 0° . | 1 |
| 9. | (c) 25. | 1 |
| 10. | Zero. | 1 |
| 11. | Remains same. | 1 |
| 12. | $^7\text{X}_3$ due to more neutrons. | 1 |
| 13. | 0 K. | 1 |
| 14. | increases. | 1 |
| 15. | Photoelectric effect. | 1 |
| 16. | (c) Assertion (A) is true, but Reason (R) is false. | 1 |
| 17. | (b) Both A and R are true and R is not the correct explanation of A. | 1 |
| 18. | (a) Both A and R are true and R is the correct explanation of A. | 1 |

SECTION-B

19.	Production of infrared waves.	1
	Reason of Calling heat waves.	1
	Infrared waves are produced by hot bodies and vibrations of molecules.	1
	They are referred as heat waves because they are readily absorbed by water molecules and increases their thermal energy and heat them.	1
<i>Or</i>		
	Production of X-rays	1
	Two uses	$\frac{1}{2} + \frac{1}{2}$

When fast moving electrons strike a heavy target like tungsten, X-rays are produced. 1

Two uses:

1. To study crystal structure. ½

2. Used as diagnostic tool in medical. ½

20. $P = +5 D$ $f_e = -100 \text{ cm}$
 $\mu_g = 1.5$ $\mu_l = ?$
 $f_a = \frac{1}{P} = \frac{1}{5} = 0.2 \text{ m} = 20 \text{ cm}$ ½

$$\frac{1}{f_a} = \left(\mu_g - 1 \right) \left(\frac{1}{R_1} - \frac{1}{R_2} \right)$$

$$\frac{1}{20} = (1.5 - 1) \left(\frac{1}{R_1} - \frac{1}{R_2} \right) \quad \dots(1) \quad ½$$

$$\frac{1}{f_l} = \left(\frac{\mu_g}{\mu_l} - 1 \right) \left(\frac{1}{R_1} - \frac{1}{R_2} \right)$$

$$\frac{1}{(-100)} = \left(\frac{1.5}{\mu_l} - 1 \right) \left(\frac{1}{R_1} - \frac{1}{R_2} \right) \quad \dots(2) \quad ½$$

From (1) and (2), on solving

$$\mu_l = \frac{5}{3} = 1.67. \quad ½$$

21.	Meaning of ionization energy	1
	Value for H-atom	1

Ionization energy is the minimum energy required to remove an electron from an isolated atom of an element. 1

The Ionization energy for hydrogen atom is 13.6 eV. 1

Or

	Def. of mass defect	1
	Relation with stability	1

Mass defect is the difference between the actual mass of the nucleus and the sum of the masses of its nucleons. 1

Greater the mass defect, greater will be the binding energy and more stable will be the nucleus. 1

22.	<i>n</i> -type	1
	<i>p</i> -type	1

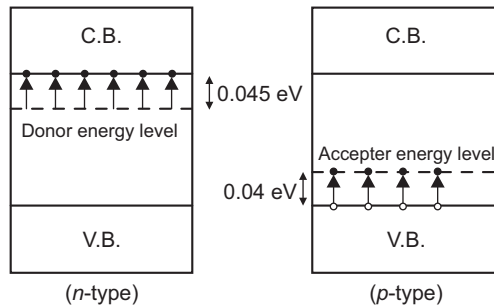

23.	Def. of magnetic susceptibility	1
	Identification of A and B	½ + ½

Magnetic susceptibility is a property which determines how easily a specimen can be magnetised when placed in the magnetic field. 1

0.96 – Diamagnetic ½

500 – Ferro magnetic ½

24.	Statement of coulomb's law	1
	Vector form	1

Two like charges attract or repel each other with a force which is directly proportional to product of magnitude of charges and inversely proportional to square of distance b/w them. 1

$$\vec{F}_{12} = \frac{1}{4\pi\epsilon_0} \frac{q_1q_2}{r_{21}^2} \hat{r}_{21} \quad 1$$

25. (1) Resistance is the opposition offered to both alternating current and direct current while impedance is the opposition offered to alternating current only. 1
- (2) Resistance is independent of frequency of source while impedance depends on frequency. 1

SECTION-C

26.	Circuit diagram	1
	Working	1
	Output waveform	1

Full-wave rectifier

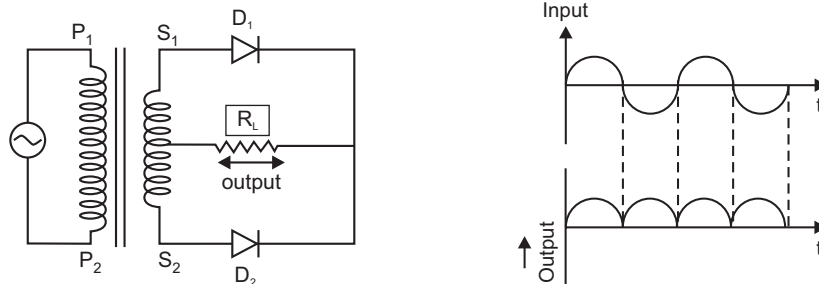

During +ve half cycle diode D_1 is forward biased and diode D_2 is reverse biased. The forward current flows due to D_1 . During -ve half cycle, diode D_1 is reverse biased and 1

diode D_2 is forward biased. The forward current flows due to D_2 . The output waveforms is shown in figure. 1

Or

V-I characteristics	1
Explanation	2

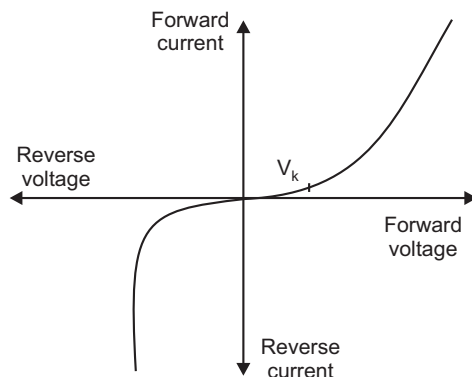

It is found that beyond forward voltage $V = V_K$ called knee voltage, the conductivity is very high. Potential barrier is overcome and the current increase rapidly.

But reverse current is due to flow of minority carriers, which is very small. 1

It shows that the diode conducts when forward biased and does not conduct when reverse biased. This characteristics makes it suitable for use for rectification. 1

27.	Def. of closest approach	1
	Formula	1
	Effect	1

The minimum distance up to which an alpha particle travel along the central line of the nucleus before it rebounds is called distance of closest approach. 1

$$r_0 = \frac{Ze(2e)}{4\pi \epsilon_0 \left(\frac{1}{2}mv^2 \right)} \quad 1$$

i.e., $r_0 \propto \frac{1}{\text{K. E}}$

As K.E doubled, r_0 is halved. 1

28.	Calculation of energy of radiation	1½
	Calculation of K.E of photoelectron	1½

(i) $E = h\nu = h \frac{C}{\lambda}$ 1½

$$= \frac{6.63 \times 10^{-34} \times 3 \times 10^8}{330 \times 10^{-9}} \quad 1½$$

$$= 6.027 \times 10^{-19} \text{ J} \quad 1½$$

(ii) K.E. of photoelectron

$$\text{K.E} = E - \phi_0 = h\nu - \phi_0 \quad 1½$$

$$= (6.02 \times 10^{-19} - 3.5 \times 10^{-19}) \quad 1\frac{1}{2}$$

$$= 2.527 \times 10^{-19} \text{ J} \quad 1\frac{1}{2}$$

29.	Expression of torque	2
	Effect of non-uniform field	1

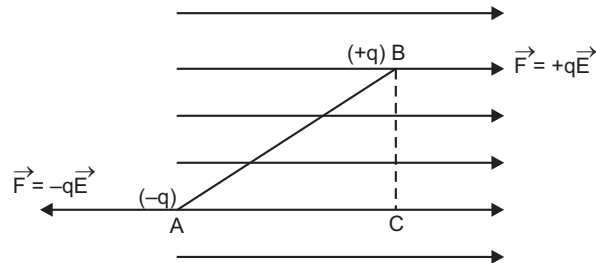

- (i) Force on $+q$, $\vec{F} = q\vec{E}$
 Force on $-q$, $\vec{F} = -q\vec{E}$
 Total force = 0 1
 $\tau = qE \times BC$
 $\therefore \tau = qE \times 2a \sin \theta$
 $\vec{\tau} = \vec{p} \times \vec{E}$ 1
- (ii) If electric field is non-uniform, then dipole experiences a translatory force as well as torque. 1

Or

Eq. Capacitance	1
Energy	1
Charge	1

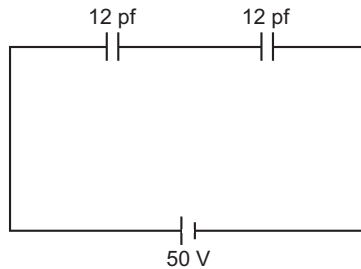

$$\frac{1}{C_s} = \frac{1}{12} + \frac{1}{12}$$

$$C_s = 6 \text{ pf} = 6 \times 10^{-12} \text{ f} \quad 1$$

$$U = \frac{1}{2} CV^2 = \frac{1}{2} \times 6 \times 10^{-12} \times 50 \times 50$$

$$= 75 \times 10^{-10} \text{ J} \quad 1$$

$$q = CV$$

$$= 6 \times 50 = 300 \times 10^{-12} \text{ C}$$

$$= 3 \times 10^{-10} \text{ C} \quad 1$$

30.	Statement of Kirchhoff's laws	1 + 1
	Justification	$\frac{1}{2} + \frac{1}{2}$
	(i) Junction Rule: At any junction, the sum of currents entering the junction is equal to the sum of currents leaving the junction.	1
	(ii) Loop Rule: The algebraic sum of all the potential differences across the elements of circuit (<i>i.e.</i> , emf of current sources and resistances) in a closed circuit is zero.	1
	Justification: The first law is in accordance with law of conservation of charge.	$\frac{1}{2}$
	The second law is in accordance with law of conservation of energy.	$\frac{1}{2}$

SECTION-D (CASE STUDY)

31. (i) (d) both *a* and *c*. 1
(ii) (b) 4 mA 1

Or

$$(\sigma) = [M^{-1} L^{-3} T^3 A^2]$$

- (iii) It is defined as the change in the resistivity per unit original resistivity per unit rise in temperature. 1
(iv) Current density (*J*) is vector quantity. 1
32. (i) The sources of light which continuously emit light of same wavelength, same frequency and of same phase are called coherent sources. 1
(ii) $x = n\lambda$ (Constructive interference) $\frac{1}{2}$
 $x = (2n + 1)\frac{\lambda}{2}$ (Destructive interference) $\frac{1}{2}$
(iii) Zero. 1

Or

A light in which vibration of light vectors are restricted in a one particular plane.

- (iv) When *d* is very large, fringe width will decrease or cannot be seen separately. 1

SECTION-E

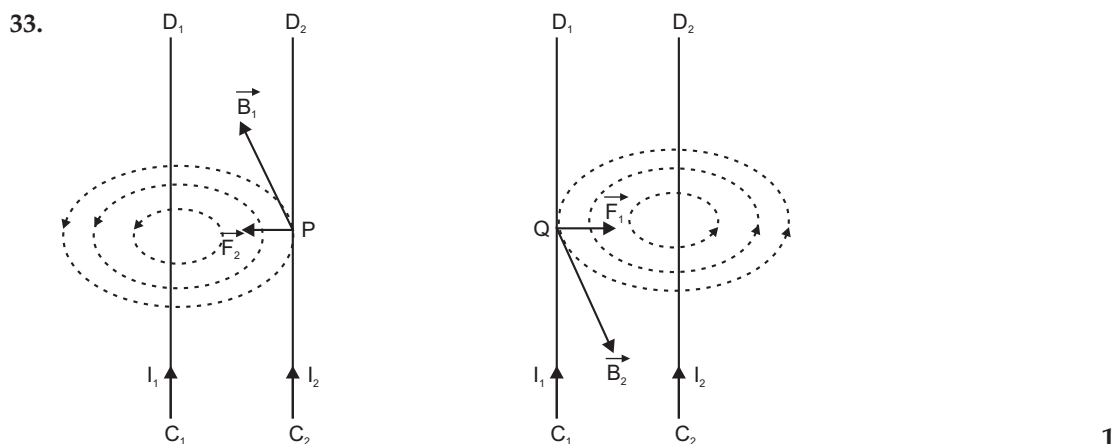

Consider C_1D_1 and C_2D_2 two infinite long straight conductors carrying currents I_1 and I_2 in same direction, at a distance r apart held \parallel^{el} to each other.

Mag. field Induction at pt. *P* on C_2D_2 due to current I_1 in C_1D_1 .

$$B_1 = \frac{\mu_0}{4\pi} \frac{2I_1}{r} \perp^{ar} \text{ to plane of paper acting inwards given by right hand rule.} \quad 1$$

∴ The unit length of $C_2 D_2$ experience a force F_2 .

$$F_2 = B_1 I_2 \times 1 = B_1 I_2$$

$$F_2 = \frac{\mu_0}{4\pi} \frac{2I_1 I_2}{r} \quad \dots(1) \quad 1$$

According to Fleming's left hand rule force on $C_2 D_2$ acts in the plane of paper \perp to $C_2 D_2$, directed towards $C_1 D_1$.

||ly $C_1 D_1$ also experience force given by equation (1), which acts in the plane of paper \perp to $C_1 D_1$ directed towards $C_2 D_2$.

Hence $C_1 D_1$ and $C_2 D_2$ attract each other carrying current in same direction. 1

One Ampere—is that much current which when flowing through each of two ||^{el} uniform long linear conductors placed in free space at a distance of 1m from each other will attract or repel each other with a force of 2×10^{-7} N/m of their length. 1

Or

Diagram	1
Principle	½
Construction	1½
Working	2

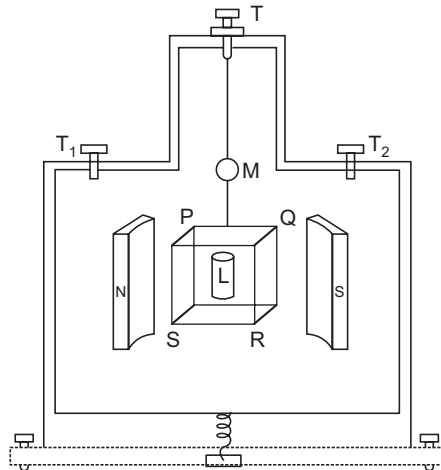

1

Principle: When a current carrying coil placed in magnetic field, it experiences a torque. ½

Construction: It consists of a rectangular coil PQRS of large no. of turns of insulated copper wire wound over a non-magnetic material frame. A soft iron cylindrical core is placed such that coil can rotate without touching it. Coil is suspended b/w two cylindrical magnets by a phosphor bronze wire. Upper end of the coil is connected to movable torsion head and lower end is connected to hair spring. 1½

Working: Function of cylindrical core and magnet is to provide radial magnetic field

$$\tau = n I A B$$

If k is the restoring torque per unit twist and Q be the twist in the wire.

In equilibrium $\tau = \tau_R$ (Restoring torque)

$$n \angle AB = K\theta$$

$$I = \frac{K\theta}{n \angle AB}$$

$$= G\theta$$

where $G = \frac{K}{n \angle AB}$ galvanometer constant

$I \propto \theta$ i.e., linear scale deflection

2

34. It is the phenomenon of reflection of light into a denser medium from an interface of this denser medium and a rarer medium. 1

Two essential conditions of TIR:

1. Light should travel from denser to rarer medium.
2. Angle of incidence in denser medium should be greater than critical angle for the pair of media in contact. 2

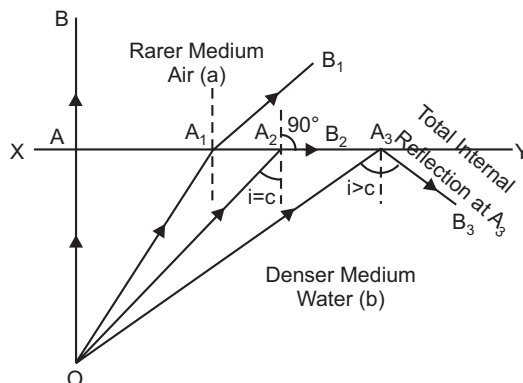

Optical fibres are the threads of glass or quartz of ref. index 1.5 coated with a thin layer of material having low ref. index nearly 1.48.

When light falls at one end of the optical fibre. The refracted ray falls with angle greater than critical angle TIR takes place and finally ray come out of other end without any loss.

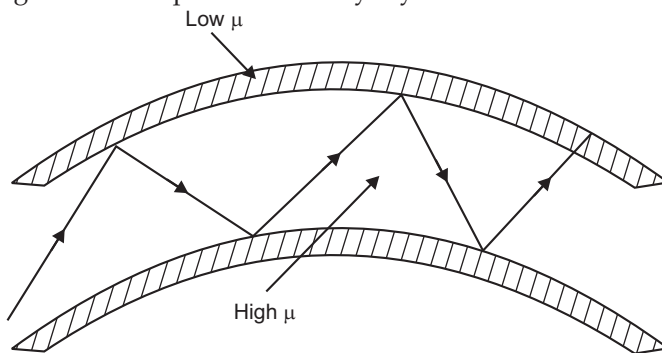

2

Or

Huygen's Principle: According to Huygen's Principle:

- (i) Every point on primary wavefront acts as fresh source of disturbance which travel in all direction with velocity of light and called as secondary wavelets. 1
- (ii) Surface obtained by joining secondary wavelets tangentially in forward direction called secondary wavefront. 1

Refraction of plane wavefront

It C_1 is the speed of light in rarer medium and C_2 is speed of light in denser medium then

$$\mu = \frac{C_1}{C_2} \quad \dots(1) \quad 1$$

AB is a plane wavefront incident on XY . According to Huygen's principle, every pt. on AB is a source of secondary wavelets.

Let secondary wavelets from B strike XY at A' in t -seconds.

$$\therefore BA' = C_1 \times t \quad \dots(2)$$

Taking $C_2 \times t$ as radius draw an arc at B' with A as a centre.

$A'B'$ is secondary wavefront.

$$\therefore AB' = C_2 \times t \quad \dots(3) \quad 1$$

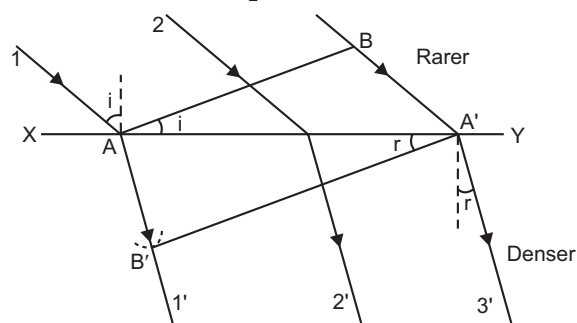

$$\text{In } \triangle AA'B \quad \sin i = \frac{BA'}{AA'} = \frac{C_1 \times t}{AA'}$$

$$\text{In } \triangle AA'B' \quad \sin r = \frac{AB'}{AA'} = \frac{C_2 \times t}{AA'}$$

$$\text{Divide} \quad \frac{\sin i}{\sin r} = \frac{C_1}{C_2} = \mu$$

$$\text{or} \quad \boxed{\mu = \frac{\sin i}{\sin r}} \quad 1$$

It is clear that incident rays, normal and refracted rays all lie in the same plane.

$$35. (i) \text{ Let } E = E_0 \sin \omega t \text{ be the alternating emf.} \quad \dots(1)$$

$$V = \frac{q}{C} = E_0 \sin \omega t$$

$$q = CE_0 \sin \omega t$$

$$I = \frac{dq}{dt} = \frac{d}{dt} (CE_0 \sin \omega t) \quad 1$$

$$= \frac{E_0}{1/\omega C} \sin(\omega t + \pi/2)$$

The current will be maximum if $\sin(\omega t + \pi/2) = 1$

$$I = I_0 = \frac{E_0}{1/\omega C}$$

$$\therefore I = I_0 \sin(\omega t + \pi/2) \quad \dots(2) \quad 1$$

It shows alternating current leads by $\pi/2$ to the alternating voltage.

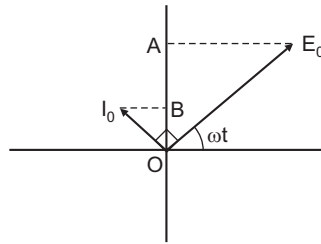

$$OA = E = E_0 \sin \omega t$$

$$OB = I = I_0 \sin (\omega t + \pi/2)$$

(ii) **Faraday's 1st law:** Whenever there is a change in the magnetic flux linked with a coil, an emf is induced in it. It lasts so long as change in flux continuous.

Faraday's 2nd law: Rate of change of magnetic flux linked with a coil is directly proportional to emf induced in it. 1

$$e = -\frac{d\phi}{dt} \quad 1$$

Or

A.C. Generator: It is a device used to convert mechanical energy into electrical energy. 1

Principle: It is based on principle of electromagnetic induction. Whenever mag. flux linked with a coil change, induced emf. produces in coil. 1

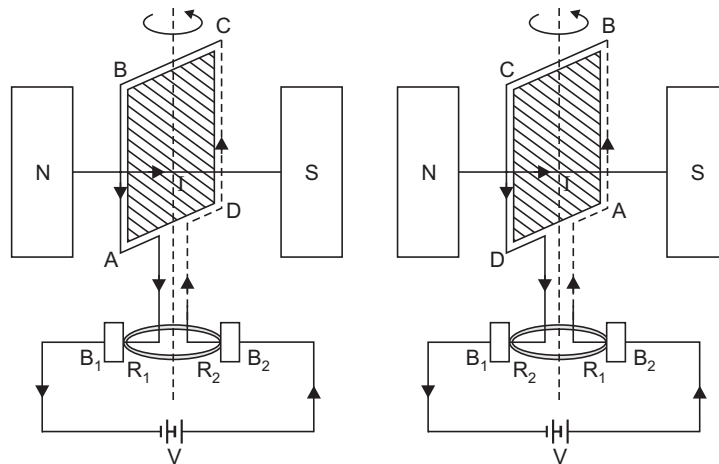

1

Working: As the armature coil is rotated in the mag. field angle θ b/w field and normal to the coil changes continuously. An emf is induced in the coil. The direction of induced current is shown in figure.

Let N = no. of turns in the coil

A = area of each turn

\vec{B} = strength of mag field

$$\phi = N(\vec{B} \cdot \vec{A}) = NBA \cos \theta$$

$$= NBA \cos \omega t$$

$$e = \frac{d\phi}{dt} = \frac{d}{dt} (NBA \cos \omega t) = -NBA\omega \sin \omega t$$

e will be max if $\sin \omega t = 1$

$$\therefore e_{\max} = e_0 = NBA\omega$$

$$\therefore e = e_0 \sin \omega t$$

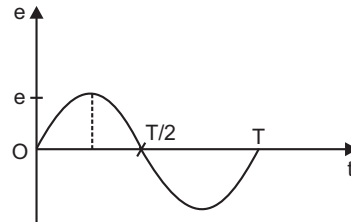

2

□□□